



# PILOT 575

PR-2575

This product manual contains important information about the safe installation and use of this projector. Please read and follow these instructions carefully and keep this manual in a safe place for future reference.

**PR LIGHTING LTD.**

No. 571, Yingbin Road, Dashi, Panyu, Guangzhou, 511430 China

<http://www.pr-lighting.com>

## INDEX

SAFE USAGE OF THE PROJECTOR	3
INSTALLING THE PROJECTOR	4
FITTING THE LAMP	4
POWER SUPPLY – MAINS	5
CONTROL CONNECTIONS	5
DMX TERMINATOR	6
SETUP OPTIONS-PROJECTOR CONFIGURATION	6
TO SET THE DMX START ADDRESS	6
FUNCTIONS DISPLAY	7
REPLACING GOBOS	9
REPLACING BELTS	9
DMX CONTROL CHANNEL FUNCTIONS	10
MAINTENANCE	15
LUBRICATION	15
KEEPING THE PROJECTOR CLEAN	15
TROUBLESHOOTING	16
TECHNICAL DATA	17
ELECTRICAL DIAGRAM	18
COMPONENT ORDER CODES	19

Please note that as part of our ongoing commitment to continuous product development, specifications are subject to change without notice. Whilst every care is taken in the preparation of this manual we reserve the right to change specifications in the course of product improvement. The publishers cannot be held responsible for the accuracy of the information herein, or any consequence arising from them.

Every unit is tested completely and packed properly by the manufacturer. Please make sure the packing and / or the unit are in good condition before installation and use. Should there be any damage caused by transportation, consult your dealer and do not use the unit. Any damage caused by improper use will not be assumed by the manufacturer and / or dealer.

## ACCESSORIES

THESE ITEMS ARE PACKED TOGETHER WITH THE PROJECTOR

- G clamps (2 PCS)
- XLR cable with 3-pin plug and socket (1 PCS)
- Safety cords (2 PCS)
- Spare gobos (3 PCS)
- This manual (1 PCS)
- Ω clamps (Options) (2PCS)

## INTRODUCTION

Thank you for purchasing our product PILOT 575, PR-2575.

This product manual contains important information about the safe installation and use of this projector. Please read and follow these instructions carefully and keep this manual in a safe place for future reference.

PILOT 575 is an innovative projector with an elegant housing, which is of Pan's and Tilt's locks for maintenance and high quality fans free from noise. The projector has 2 types of clamps for mounting at any direction and position. Which complies to CE norms and standards and uses international protocol DMX 512.

The projector uses MSR575 discharge lamp and high quality optical system, which produces bright and beautiful light beam and has 60% output lumen more than the similar products with the same power consumption. The projector features effects of strobe, frost light, mixed colours and rainbow, so it is suitable for applications in TV station, disc, singing and dancing stage, nightclub, etc.

## SAFE USAGE OF THE PROJECTOR



When unpacking and before disposing of the carton check there is no transportation damage before using the projector. Should there be any damage caused by transportation, consult your dealer and do not use the apparatus.

The projector is for indoor use only, IP20. Use only in dry locations. Keep this device away from rain and moisture, excessive heat, humidity and dust. Do not allow contact with water or any other liquids.

The projector is not designed or intended to be mounted directly on to inflammable surfaces. 

The projector is only intended for installation, operation and maintenance by qualified personnel.

The projector must be installed in a location with adequate ventilation, at least 50cm from adjacent wall surfaces. Be sure that no ventilation slots are blocked.

Do not project the beam onto inflammable surfaces, minimum distance is 5m.  5m 

Avoid direct exposure to the light from the lamp. The light is harmful to the eye.

Do not attempt to dismantle and/or modify the projector in any way.

Electrical connection must only be carried out by qualified personnel.

Before installation, ensure that the voltage and frequency of power supply match the power requirements of the projector.

It is essential that each projector is correctly earthed and that electrical installation conforms to all relevant standards.

Do not connect this device to any other types of dimmer apparatus.

Make sure that the power-cord is never crimped or damaged by sharp edges. Never let the power-cord come into contact with other cables. Only handle the power-cord by the plug. Never pull out the plug by tugging the power-cord.

Keep the lamp clean. Do not touch the lamp glass with bare hand.

The projector should always be installed with a secondary safety fixing. A safety cord is supplied for this; it should be attached as shown in "installing the projector" section.

The lamp used in this projector is a Philips MSR575 discharge lamp. After switching off don't attempt to restart the projector until lamp has cooled, this will require approx 15 minutes. Switching the lamp on and off at short intervals will reduce the life of both the lamp and the projector. But occasional breaks will prolong the life of the lamp and projector.

Never run the projector without a lamp.

There is no user serviceable parts inside the projector do not open the housing and never operate the projector with the covers removed.

**Always disconnect from the mains, when the device is not in use or before cleaning it or before attempting any maintenance work.**

If you have any questions, don't hesitate to consult your dealer or manufacturer.

## INSTALLING THE PROJECTOR

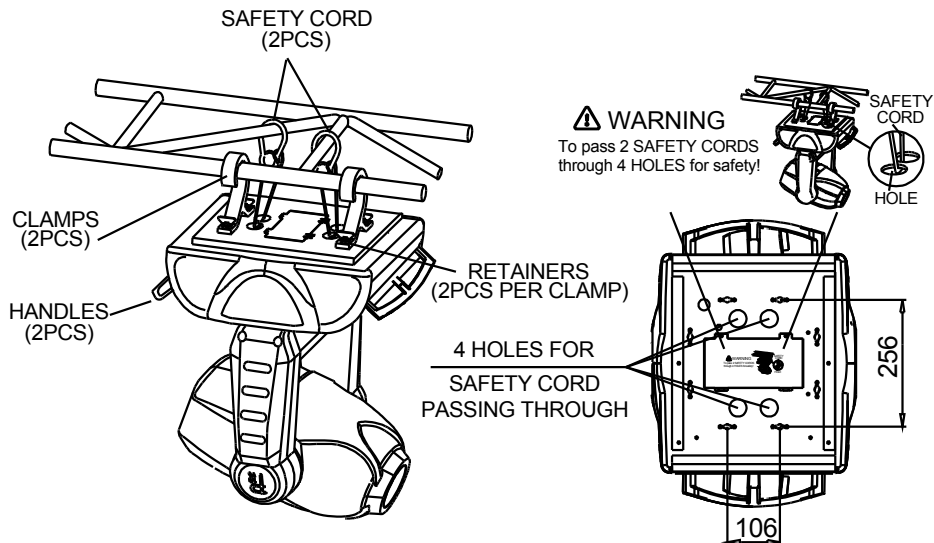

Take 2 clamps and 2 safety cords out from the package and mount 2 clamps on the underside of fixture with 2 retainers attached to each clamp. Hang the fixture on the structure and fasten the screws attached to each clamp. (Watch the **WARNING** on the underside of the base as shown above) **To pass 2 SAFETY CORDS through 4 HOLES for safety!** Always ensure that the projector is firmly anchored to avoid vibration and slipping whilst functioning. Always ensure that the structure that you are going to mount the projector is secure and is strong enough to support a weight of PILOT 575.

**WARNING:** 1. Unlock the PAN and TILT before the 1<sup>st</sup> application of projector for safety.  
2. The projector **MUST** be lifted or carried by the HANDLES instead of clamps.

## FITTING THE LAMP

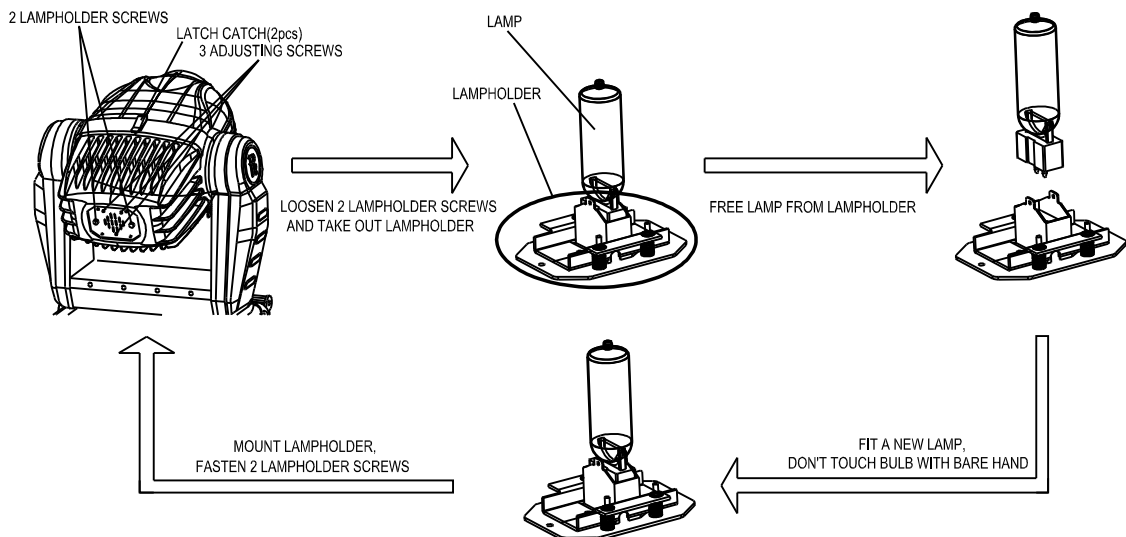

Lock tilt before fitting/replacing the lamp.  
(Do the way as shown in the above figure)

Loosen 2 lampholder screws as shown in the above figure and take out the lampholder.

Free worn-out lamp from lampholder.

Fit a new lamp and insert it with lampholder into the fixture, then fasten 2 lampholder screws.

After the fitting is done, turn the projector on and 5 minutes later adjust 3 adjusting screws to focus for the best light output.

**Notes:** don't touch the bulb of the new lamp with bare hand so as not to influence the beam output.

**WARNING:** The MSR series are high-pressure lamps with external igniters (⚠). Care should always be taken when handling these lamps. Always read the manufacturers "Instructions for use" enclosed with the lamp.

## POWER SUPPLY - MAINS

Connect the power cord as follows:

- L (live) =brown
- E (earth) =yellow/green
- N (neutral) =blue

Use the plug provided to connect the mains power to the projector paying attention to the voltage and frequency marked on the panel of the projector. It is recommended that each projector be supplied separately so that they may be individually switched on and off.

### IMPORTANT

**It is essential that each projector is correctly earthed and the electrical installation conforms to all relevant standards. Power consumption of the PILOT 575 is 780W.**

## CONTROL CONNECTIONS

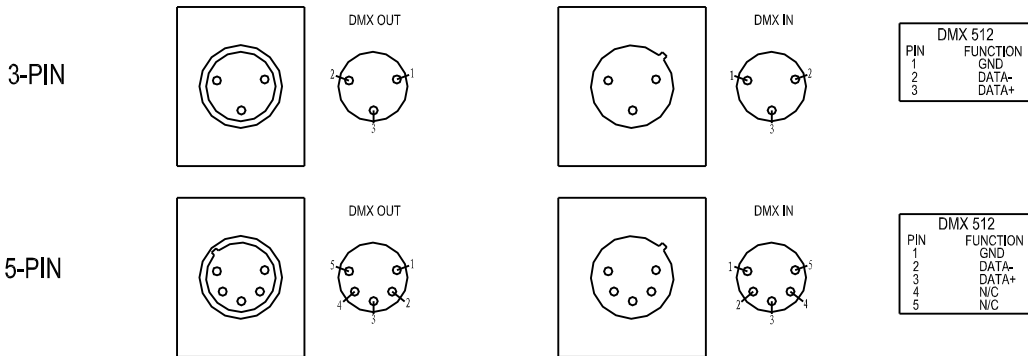

Connection between controller and projector and between one projector and another must be made with 2 core-screened cables, with each core having at least a 0.5mm diameter. Connection to and from the projector is via cannon 3 pin (which are included with the projector) or 5 pin XLR plugs and sockets. The XLR's are connected as shown in the figure above.

Note: care should be taken to ensure that none of the pins touch the metallic body of the plug or each other. The body of the plug is not connected in any way. The PILOT 575 accepts digital control signals in protocol DMX512 (1990).

Connect the controller's output to the first fixture's input, and connect the first fixture's output to the second fixture's input and connect the rest fixtures in the same way. Eventually connect the last fixture's output to a DMX terminator as shown in the figure below.

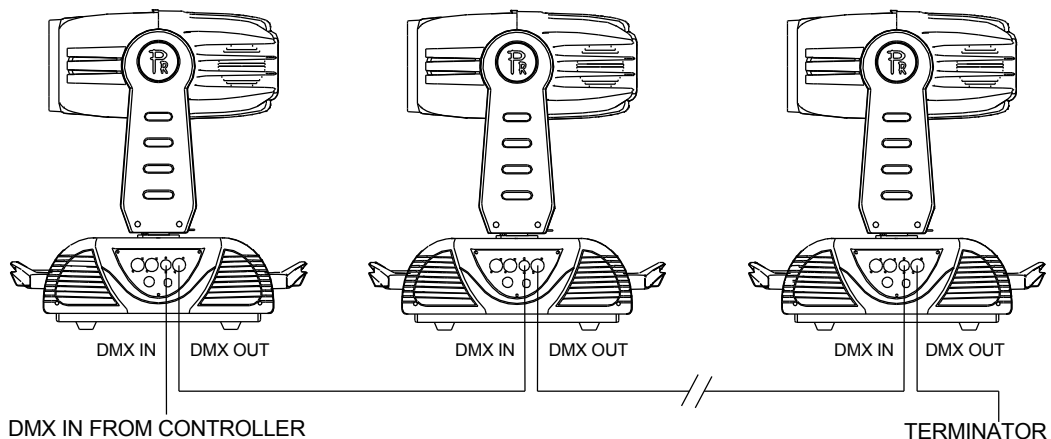

## DMX TERMINATOR

In the Controller mode, at the last fixture in the chain, the DMX output has to be connected with a DMX terminator. This prevents electrical noise from disturbing and corrupting the DMX control signals. The DMX terminator is simply an XLR connector with a 120Ω (ohm) resistor connected across pins 2 and 3, which is then plugged into the output socket on the last projector in the chain. The connections are illustrated below.

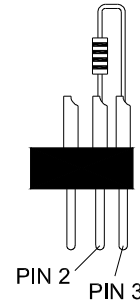
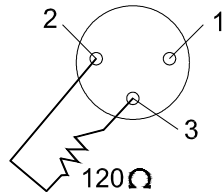

## SETUP OPTIONS - PROJECTOR CONFIGURATION

Connect a 120(OHM) resistor across pins 2 and 3 in an XLR plug and insert into the DMX OUT socket on the last unit in the chain.

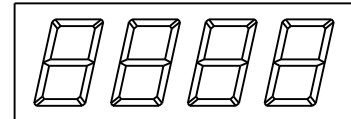

FUNC DOWN UP ENTER

Projector configuration can be set conveniently via pressbutton switch and digital display. Turn the projector on and the digital display will show DMX address you set and save last time and it can be reset and saved again as you please.

Press button **UP** or **DOWN** if you want to browse through the various Setup Options.

Press button **ENTER** to save your settings or enter the next menu. Press button **UP** or **DOWN** to shift the display between **On** and **OFF** or change the display of address.

Press button **FUNC**, it will return to the upper menu one by one. The display will return automatically to the function of address display if you stay for about 60 seconds defaulted.

## TO SET THE DMX START ADDRESS

Each PILOT 575 must be given a DMX start address so that the correct projector responds to the correct control signals. This DMX start address is the channel number from which the projector starts to "listen" to the digital control information being sent out from the controller. The PILOT 575 has 19 channels, so set the No. 1 projector's address 001, No. 2 projector's address 020, No. 3 projector's address 039, No. 4 projector's address 058, and so on.

Launch the projector. Press button **ENTER** more than 5 seconds to unlock panel.

Press button **FUNC** to **Addr**; press button **ENTER**, it will display address; press button **UP** and **DOWN**, you can set the address; press button **ENTER** to confirm.

# FUNCTIONS DISPLAY

**ADDR** SET ADDR. (Default: 001)  
**001** ADDR. 001

**RST** RESET MENU  
**RST?** RESET OR NOT

**CNFG** CONFIG. MENU  
**HRES** SET DMX EXT. CHANNEL (Default : ON)  
**ON** DMX EXT. CHANNEL ENABLED  
**OFF** DMX EXT. CHANNEL DISABLED  
**CTRL** SET DMX CONTROL CHANNEL (Default : ON)  
**ON** DMX CONTROL CHANNEL ENABLED  
**OFF** DMX CONTROL CHANNEL DISABLED  
**LAMP** SET LAMP CONTROL MODE (Default:CTRL)  
**CTRL** BY CONTROL CHANNEL  
**ON** BY LAMP MENU  
**DMX** BY DMX SIGNAL EXISTING OR NOT

**OPTN** OPTION MENU  
**COLR** SET COLOUR FILTERS (Default :STEP)  
**STEP** LINEAR ROTATION DISABLED  
**LIN** LINEAR ROTATION ENABLED  
**GOBO** SET GOBO POSITION (Default :STEP)  
**STEP** LINEAR ROTATION DISABLED  
**LIN** LINEAR ROTATION ENABLED  
**PAN** SET ROTATION OF PAN (Default:OFF)  
**OFF** FORWARD ROTATION  
**ON** REVERSE ROTATION  
**TILT** SET ROTATION OF TILT (Default:OFF)  
**OFF** FORWARD ROTATION  
**ON** REVERSE ROTATION  
**PANS** SET PAN&TILT SWAP (Default:OFF)  
**OFF** PAN&TILT SWAP OFF  
**ON** PAN&TILT SWAP ON  
**DIMIN** SET DIMMER INVERT(Defaultaa:OFF)  
**OFF** DIMMER INVERT OFF  
**ON** DIMMER INVERT ON  
**IRES** SET IRES INVERT(Defaultaa:OFF)  
**OFF** IRES INVERT OFF  
**ON** IRES INVERT ON  
**dFLT** RESET (Default : OFF)  
**OFF** DISABLED  
**ON** ENABLED AND LOAD ALL DEFAULTS

**DISP** DISPLAY MENU(Default : ON)  
**PAMP** LCD OF PANEL DISPLAY MODE  
**ON** LCD IS ON  
**OFF** LCD IS OFF AFTER DELY  
**DM** LCD IS DARK

(CONTINUE)

**INFO** INFORMATION MENU

**L\HR** DISPLAY LAMP'S USING TIME OR SET TO 0  
 DISPLAY PROJECTOR'S USING TIME

**RSTP** RESET OR NOT

**T\HR** DISPLAY PROJECTOR'S USING TIME OR SET TO 0  
 DISPLAY PROJECTOR'S USING TIME

**TEMP** DISPLAY TEMPERATURE

**MSTR** DISPLAY MAIN PCB'S TEMPERATUER

**DRV1** DISPLAY DRIVER PCB I 'S TEMPERATURE

**DRV2** DISPLAY DRIVER PCB II'S TEMPERATURE

**BASE** DISPLAY PAN&TILT DRIVER PCB'S TEMPERATURE

**HEAD** RESERVED  
 N/A

**VER** DISPLAY PROGRAM VERSION

**MSTR** DISPLAY MAIN PCB'S PROGRAM VER.

**DRV1** DISPLAY MOTOR DRIVER PCB I 'S PROGRAM VER.

**DRV2** DISPLAY MOTOR DRIVER PCB II 'S PROGRAM VER.

**P\T** DISPLAY PAN&TILT DRIVER PCB'S PROGRAM VER.

**PWR** DISPLAY POWER PCB'S PROGRAM VER.

**TEST** TEST MENU

**SET** DEBUG MODE (Default:OFF)  
 OFF EXIT DEBUG MODE AND RESET  
 ON ACCESS DEBUG MODE

**SELF** SELF-TEST MODE (Default:OFF)  
 OFF EXIT SELF-TEST MODE AND RESET  
 ON ACCESS SELF-TEST MODE

**LAMP** LAMP MENU (Default: STAT)

**STAT** DISPLAY STATE OF LAMP  
 ON  
 OFF

(END)

## REPLACING GOBOS

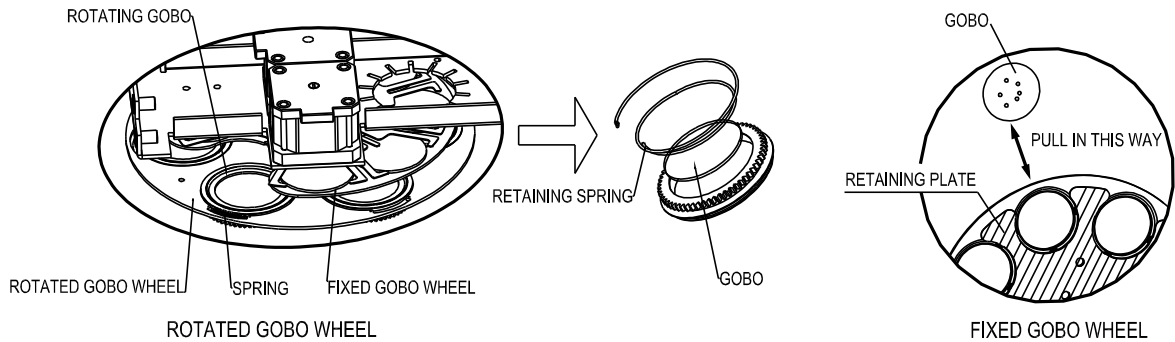

Lock Tilt.

Free 2 latch catches on the cover and slip off the front cover. You could see the structure as shown in the above figure.

For gobos replacement on the rotated gobo wheel: take an appropriate tool to tug up spring and take out the rotating gobo with its holder; tug the head of retaining spring up and engage your another hand to take the retaining spring out; take the gobo out; fit a new gobo and fit the retaining spring; fit the lampholder. Notes: the gobo cannot be touched with bare hand; be careful of the gobo when the replacement is underway and don't drop it.

For gobos replacement on the fixed gobo wheel: turn the rotated gobo wheel to a proper position first; take out a gobo from the fixed gobo wheel carefully; fit a new gobo. Note: if the gobo is a glass one, it should be touched with glabrous, clean and soft tissue or cloth matted between hand and glass instead of with bare hand.

Close the front cover and fasten 2 latch catches.

## CHANGING BELTS

### Pan's belts

Free 2 screws on Pan assembly's maintenance door and open the door; change the belts; close the door and fasten the screws.

### Tilt's belts

The common users replacing the belts is not recommended.

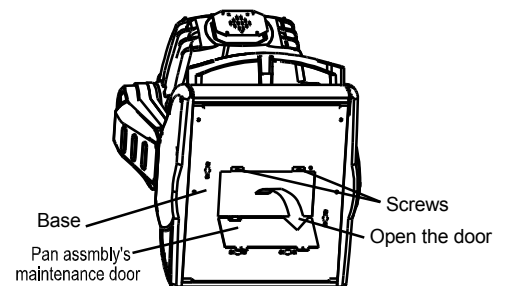

## DMX CONTROL CHANNEL FUNCTIONS

The PILOT 575 uses 19 DMX channels. They are listed in the following table.

Channel	Function	DMX Value	Description
1	Strobe	000-009	Blackout
		010-020	Open
		021-034	Strobe 1
		035-048	Strobe 2
		049-062	Strobe 3
		063-076	Strobe 4
		077-090	Strobe 5
		091-104	Strobe 6
		105-118	Strobe 7
		119-132	Strobe 8
		133-146	Strobe 9
		147-160	Strobe 10
		161-174	Strobe 11
		175-188	Strobe 12
		189-202	Strobe 13
		203-216	Strobe 14
		217-230	Strobe 15
231-244	Strobe 16		
245-255	Open		
2	Dimmer	000-255	0 to 100% dimming
3	Iris	000-255	Linear adjust iris from open to closed
4	Fixed Gobos	000-020	Clear
		021-040	Gobo 1
		041-060	Gobo 2
		061-080	Gobo 3
		081-100	Gobo 4
		101-120	Gobo 5
		121-140	Gobo 6
		141-160	Gobo 7
		161-167	Rotation speed 1 (slowest)
		168-175	Rotation speed 2
		176-183	Rotation speed 3
		184-191	Rotation speed 4 (fastest)
		192-207	Stop rotating
		208-231	Reverse rotation speed 1 (slowest)
		232-239	Reverse rotation speed 2
		240-247	Reverse rotation speed 3
		248-255	Reverse rotation speed 4 (fastest)
5	Pan rotation	000-255	Pan rotation from 0 to 540°

6	Tilt rotation	000-255	Tilt rotation from 0 to 270°
7	Focus	000-255	Linear adjust iris from near to far
8	Zoom	000-050	Clear
		051-101	Angle 1 (wide)
		102-152	Angle 2 (narrow)
		153-203	UV effect
		204-255	Frost
9	Colour Wheel 1	000-016	White. Note: stay 5 seconds while DMX value is 5, 6 or 7, the function reset perform
		017-024	White/colour filter 1
		025-032	Colour filter 1
		033-040	Colour filter 1/colour filter 2
		041-048	Colour filter 2
		049-056	Colour filter 2/colour filter 3
		057-064	Colour filter 3
		065-072	Colour filter 3/colour filter 4
		073-080	Colour filter 4
		081-088	Colour filter 4/colour filter 5
		089-096	Colour filter 5
		097-104	Colour filter 5/colour filter 6
		105-112	Colour filter 6
		113-120	Colour filter 6/white
		121-127	White
		128-133	Rotation speed 1
		134-139	Rotation speed 2
		140-145	Rotation speed 3
		146-151	Rotation speed 4
		152-157	Rotation speed 5
		158-163	Rotation speed 6
		164-169	Rotation speed 7
		170-175	Rotation speed 8
		176-181	Rotation speed 9
		182-187	Rotation speed 10
		188-195	Stop rotating
		196-201	Reverse rotation speed 1
		202-207	Reverse rotation speed 2
		208-213	Reverse rotation speed 3
		214-219	Reverse rotation speed 4
		220-225	Reverse rotation speed 5
		226-231	Reverse rotation speed 6
		232-237	Reverse rotation speed 7
		238-243	Reverse rotation speed 8
		244-249	Reverse rotation speed 9

		250-255	Reverse rotation speed 10
10	Colour Wheel 2	000-016	White
		017-024	White/colour filter 1
		025-032	Colour filter 1
		033-040	Colour filter 1/colour filter 2
		041-048	Colour filter 2
		049-056	Colour filter 2/colour filter 3
		057-064	Colour filter 3
		065-072	Colour filter 3/colour filter 4
		073-080	Colour filter 4
		081-088	Colour filter 4/colour filter 5
		089-096	Colour filter 5
		097-104	Colour filter 5/colour filter 6
		105-112	Colour filter 6
		113-120	Colour filter 6/white
		121-127	White
		128-133	Rotation speed 1
		134-139	Rotation speed 2
		140-145	Rotation speed 3
		146-151	Rotation speed 4
		152-157	Rotation speed 5
		158-163	Rotation speed 6
		164-169	Rotation speed 7
		170-175	Rotation speed 8
		176-181	Rotation speed 9
		182-187	Rotation speed 10
		188-195	Stop rotating
		196-201	Reverse rotation speed 1
		202-207	Reverse rotation speed 2
		208-213	Reverse rotation speed 3
		214-219	Reverse rotation speed 4
		220-225	Reverse rotation speed 5
		226-231	Reverse rotation speed 6
		232-237	Reverse rotation speed 7
		238-243	Reverse rotation speed 8
		244-249	Reverse rotation speed 9
		250-255	Reverse rotation speed 10
11	Rotating Gobo Wheel	000-043	Clear
		044-085	Gobo 1
		086-128	Gobo 2
		129-170	Gobo 3
		171-212	Gobo 4
		213-255	Gobo 5
12	Gobo Rotation	000-120	(Rotating gobo) 0~540° index
		121-127	(Rotating gobo) Rotation speed 1

		128-135	(Rotating gobo) Rotation speed 2
		136-143	(Rotating gobo) Rotation speed 3
		144-151	(Rotating gobo) Rotation speed 4
		152-159	(Rotating gobo) Rotation speed 5
		160-167	(Rotating gobo) Rotation speed 6
		168-175	(Rotating gobo) Rotation speed 7
		176-183	(Rotating gobo) Rotation speed 8
		184-191	(Rotating gobo) stop rotating
		192-199	(Rotating gobo) reverse rotation speed 8
		200-207	(Rotating gobo) reverse rotation speed 7
		208-215	(Rotating gobo) reverse rotation speed 6
		216-223	(Rotating gobo) reverse rotation speed 5
		224-231	(Rotating gobo) reverse rotation speed 4
		232-239	(Rotating gobo) reverse rotation speed 3
		240-247	(Rotating gobo) reverse rotation speed 2
		248-255	(Rotating gobo) reverse rotation speed 1
13	Prisms	000-051	Clear
		052-102	Prism 1
		103-153	Prism 2
		154-204	CTB
		205-255	CTO
14	Prism Rotation	000-120	(Prism) 0~540° index
		121-127	(Prism) Rotation speed 1
		128-135	(Prism) Rotation speed 2
		136-143	(Prism) Rotation speed 3
		144-151	(Prism) Rotation speed 4
		152-159	(Prism) Rotation speed 5
		160-167	(Prism) Rotation speed 6
		168-175	(Prism) Rotation speed 7
		176-183	(Prism) Rotation speed 8
		184-191	(Prism) stop rotating
		192-199	(Prism) reverse rotation speed 8
		200-207	(Prism) reverse rotation speed 7
		208-215	(Prism) reverse rotation speed 6
		216-223	(Prism) reverse rotation speed 5
		224-231	(Prism) reverse rotation speed 4
		232-239	(Prism) reverse rotation speed 3
		240-247	(Prism) reverse rotation speed 2
		248-255	(Prism) reverse rotation speed 1
15	Pan & Tilt Speed (extended function)	000-255	Adjust Pan&Tilt speed
16	Pan Fine (16Bit) (extended function)	000-255	Adjust Pan in 16Bit resolution
17	Tilt Fine (16Bit) (extended function)	000-255	Adjust Tilt in 16Bit resolution
18	Gobo Rotation Fine	000-255	Adjust gobo rotation in 16Bit resolution

	(extended function)		
19	Control (when extended functions are invalid, shift this channel to 15 <sup>th</sup> channel.)	000-048	Reserve
		049-080	Reset
		081-112	Reserve
		113-144	Turn lamp off (stay 10 seconds)
		145-223	Reserve
		224-255	Turn lamp on (see remark below)

**Remark:**

If you intend to turn on/off the lamp via the 19<sup>th</sup> channel of the controller, don't attempt to push the handle of 19<sup>th</sup> channel to value 224-255 immediately after turning it off, or push the handle to value 224-255 to wait it cooling. Under these 2 circumstances, the lamp can not be turned on. The right operation is: turn it off---cool down---push the handle to turn it on.

## MAINTENANCE

If the projector's lens becomes damaged or broken it should be replaced. If the lamp becomes damaged or deformed in any way it must be replaced. If the light from the lamp appears dim this would normally indicate that it is reaching the end of its life and it should be changed at once, aged lamps run to the extremity of their life might explode. If the projector does not function, check the fuses on the power socket of the projector, they should only be replaced by fuses of the same specification. Should these be damaged call a qualified technician before replacement. The projector has thermal protection device that will switch off the projector in case of overheating, should either of these operation, check that the fans are not blocked, and if they are dirty clean them before switching on the projector again. Check that the fans are operational, if not call a qualified technician.

**Any maintenance work should only be carried out by qualified technicians.**

## LUBRICATION

To ensure the continuous rotation of the rotating gobos and linear motion of the lens for focusing, it is recommended that the bearings for the rotating gobos and the 3 shafts for the focusing lens holder be lubricated periodically, preferably every two months. Use only high quality, high-temperature resistant grease instead of any type of oil. When lubricating the bearings, a syringe with a fine needle is the easiest way to introduce the grease to the bearings around each gobo.

## KEEPING THE PROJECTOR CLEAN

To ensure the reliability of the projector it should be kept clean. It is recommended that the fans should be cleaned every 15 days. The lens and dichroic colour filters should also be regularly cleaned to maintain an optimum light output. **Do NOT use any type of solvent on dichroic colour filters.**

Cleaning frequency depends on the environment in which the fixture operates: damp, smoke or particularly dirty surroundings can cause greater accumulation of dirt on the unit's optics. A soft cloth and typical glass cleaning products should be used in cleaning. It is recommended to clean the external optics at least once every 20 days and clean the internal optics at least once every 30 / 60 days.

**Do not use any organic solvent, e.g. alcohol, to clean the reflector mirror, dichroic colour filters or housing of the apparatus.**

## TROUBLESHOOTING

PROBLEM	POSSIBLE CAUSE	ACTION
The projector doesn't switch on	-The power supply is not present -The lamp doesn't work	Check the fuse on the power socket. Replace the lamp.
The lamp comes on but the projector doesn't respond to the controller	-Wrong DMX configuration and/or start address - Defective DMX cable	Make sure that the projector is correctly configured. Replace or repair the DMX cable.
The projector only functions intermittently	-The fan has failed	Make sure the fan is working and not dirty.
Defective projection	-The lens is broken -Dust or grease on lenses	Check the lenses are not broken. Remove dust or grease from the lenses.
The projected image appears to have a halo	-Installation of the lamp is not correct -Dust or grease contamination on the optics.	Make sure the lamp is installed correctly. Carefully clean the optical group lenses and the projector components.
The beam appears dim	-Dust or grease contamination on the optics. -The lamp is at the end of its life	Check the optics is clean.  Replace with a new lamp of the specified type and rating.

### LIGHT OUTPUT

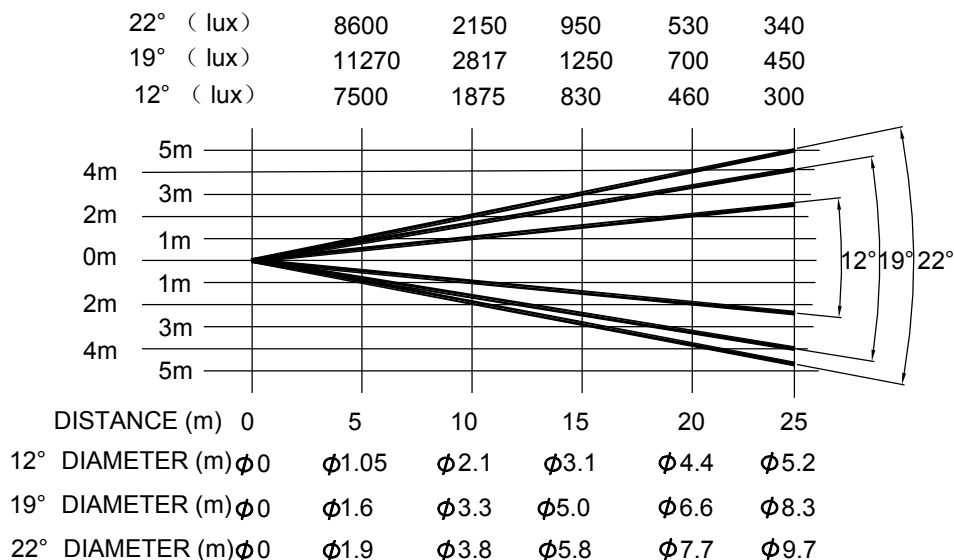

## TECHNICAL DATA

<b>VOLTAGES:</b>	100/120/200/220/230/245V AC, 50Hz or 60Hz to order
<b>POWER CONSUMPTION:</b>	700W
<b>LAMP:</b>	Type: Philips MSR 575/2 discharge lamp Colour Temperature: 7200°K Socket: GX9.5, single end Manufacturers Rated Lamp Life: 1000 Hours
<b>COLOURS:</b>	2 colour wheels 6 dichroic colours plus white each wheel Adjustable speed with rainbow effect
<b>COLOUR TEMPERATURE CORRECTION:</b>	1 colour temperature corrective filters
<b>GOBOS:</b>	<b>Rotated gobo wheel</b> 5 interchangeable gobos+white, indexical, bidirectionally rotatable in adjustable speed respectively <b>Fixed gobo wheel</b> 7 interchangeable gobos+white, bidirectionally rotatable in adjustable speed wholly Gobo diameter: 36.3mm Gobo image diameter: 31.5mm
<b>PRISM WHEEL:</b>	1x white, 1x 5 facet prism, 1x 3 Facet prism, 1x CTO, 1x frost
<b>FOCUS:</b>	DMX controlled focus
<b>EFFECT WHEEL:</b>	1x white, 1x big angle filter, 1x small angle filter, 1x ultraviolet filter 1x double-colour filter
<b>SHUTTER:</b>	Double shutter blades, 0-100% linearly adjustable
<b>STROBE:</b>	0.3~6 F.P.S.
<b>HEAD MOVEMENT:</b>	Pan 540°, Tilt 270°
<b>BEAM ANGLE:</b>	12°, 19°, 22°
<b>CONTROL:</b>	DMX512, 19 Channels
<b>HOUSING:</b>	Composite plastic (IP20)
<b>NET WEIGHT:</b>	200/220/230/240V: 33Kg 100/120V: 36Kg
<b>SIZES:</b>	

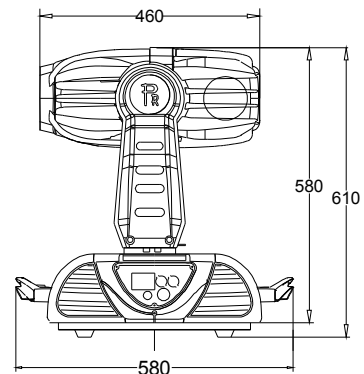
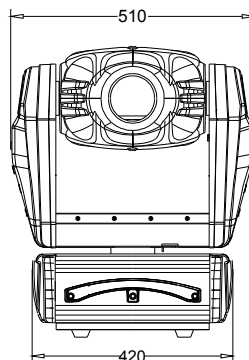
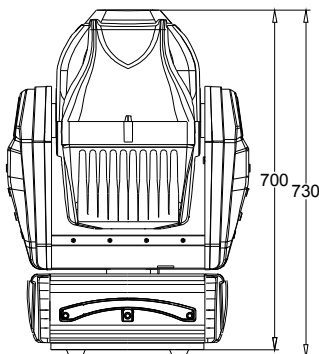

# ELECTRICAL DIAGRAM

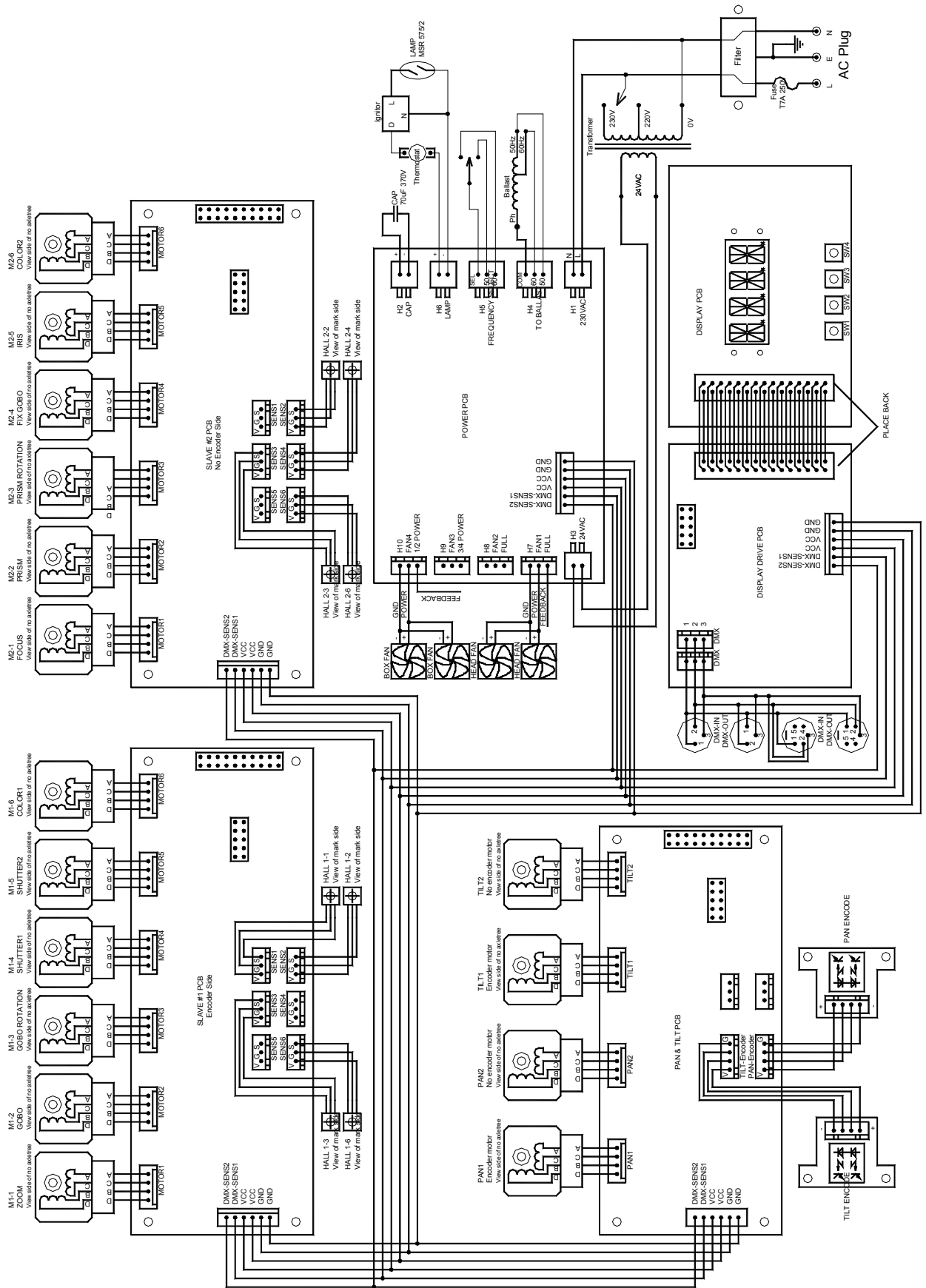

# COMPONENT ORDER CODES

NAME	PART NO.	QUANTITY	REMARK
TRANSFORMER	040030061	1	220/230V
	040030052	1	100/120V
	040030051	1	200/245V
THERMOSTAT	190010035	1	KSD020 120°C/15A/250V
CAPACITOR	140010043	1	70µF/370V
BALLAST	040070059	1	230V/50-60Hz, 575W
IGNITOR	040090035	1	575~1200W 3~5KV
LAMP	100050058	1	MSR 575W/2
FUSE	270041054	1	65TS 10A/250V 6.35*20
PAN&TILT DRIVE BELT	290151221	2	HTD459-3M-6
FANS	030060048	3	KD2409PTB1-6 24VDC
FANS	030060049	2	KD2406PTS1-6 24VDC12.6W
PAN MOTOR	030040089	1	23HS2039L 6.35X25
TILT MOTOR	030040089	1	23HS2039L 6.35X25
ZOOM/FOCUS MOTOR	030040090		16HY7001-16L TR6.5 L77
PRISM WHEEL MOTOR	030040096	1	42BYGH016-15A 5*23
IRIS MOTOR	030040122	1	42BYGH016-14A
FIXED GOBO WHEEL	030040124	1	42BYGH016-3A
PRISM ROTATION MOTOR	030040124	1	42BYGH016-3A
COLOUR WHEEL 1 MOTOR	030040124	1	42BYGH016-3A
ANGLE WHEEL MOTOR	030040125	1	42BYGH016-11A
GOBO ROTATION WHEEL	030040125	1	42BYGH016-11A
STROBE MOTOR	030040125	2	42BYGH016-11A
ROTATING GOBO MOTOR	030040126	1	42BYGH016-13A
COLOUR WHEEL 2 MOTOR	030040126	1	42BYGH016-13A
PAN & TILT DRIVER PCB	230020125	1	
MOTOR DRIVER PCB I	230020092	1	
MOTOR DRIVER PCB II	230020094	1	
DIGITAL DRIVER PCB	230020090	1	
POWER PCB	230020098	1	

## PR LIGHTING LTD.

---

No. 571, Yingbin Road, Dashi, Panyu, Guangzhou, China

Post-Code: 511430

TEL: +86-20-8478 1888

FAX: +86-20-8478 6023

---

P/N: 321010226  
Last Revision: 07:05:2006