



XL 700

PR-2700

This product manual contains important information about the safe installation and use of this projector. Please read and follow these instructions carefully and keep this manual in a safe place for future reference.

PR LIGHTING LTD.
<http://www.pr-lighting.com>

INDEX

SAFE USAGE OF THE PROJECTOR	3
INSTALLING THE PROJECTOR	4
FITTING THE LAMP	4
POWER SUPPLY – MAINS	5
CONTROL CONNECTIONS	5
DMX TERMINATOR	6
SETUP OPTIONS-PROJECTOR CONFIGURATION	6
TO SET THE DMX START ADDRESS	6
OPERATION MENU	8
ERROR MESSAGES	11
REPLACING GOBOS	11
DMX PROTOCOL	12
LED INDICATION	16
MAINTENANCE	16
LUBRICATION	16
KEEPING THE PROJECTOR CLEAN	16
TROUBLESHOOTING	17
TECHNICAL DATA	18
ELECTRICAL DIAGRAM	21
COMPONENT ORDER CODES	22

Please note that as part of our ongoing commitment to continuous product development, specifications are subject to change without notice. Whilst every care is taken in the preparation of this manual we reserve the right to change specifications in the course of product improvement. The publishers cannot be held responsible for the accuracy of the information herein, or any consequence arising from them.

Every unit is tested completely and packed properly by the manufacturer. Please make sure the packing and / or the unit are in good condition before installation and use. Should there be any damage caused by transportation, consult your dealer and do not use the unit. Any damage caused by improper use will not be assumed by the manufacturer and / or dealer.

ACCESSORIES

These items are packed together with the projector:

Name	Quantity	Unit	Remark
G clamps	2	Pcs	
3-pin XLR connector	1	Set	Without cable
Safety cord	2	Pcs	
Spare gobos	4	Pcs	
This manual	1	Pc	
Ω clamps	2	Pcs	Options

SAFE USAGE OF THE PROJECTOR



When unpacking and before disposing of the carton check there is no transportation damage before using the projector. Should there be any damage caused by transportation, consult your dealer and do not use the apparatus.

The projector is for indoor use only, IP20. Use only in dry locations. Keep this device away from rain and moisture, excessive heat, humidity and dust. Do not allow contact with water or any other liquids.

The projector is not designed or intended to be mounted directly on to inflammable surfaces. 

The projector is only intended for installation, operation and maintenance by qualified personnel.

The projector must be installed in a location with adequate ventilation, at least 50cm from adjacent wall surfaces. Be sure that no ventilation slots are blocked.

Do not project the beam onto inflammable surfaces, minimum distance is 5m.  5m 

Avoid direct exposure to the light from the lamp. The light is harmful to the eye.

Do not attempt to dismantle and/or modify the projector in any way.

Electrical connection must only be carried out by qualified personnel.

Before installation, ensure that the voltage and frequency of power supply match the power requirements of the projector.

It is essential that each projector is correctly earthed and that electrical installation conforms to all relevant standards.

Do not connect this device to any other types of dimmer apparatus.

Make sure that the power-cord is never crimped or damaged by sharp edges. Never let the power-cord come into contact with other cables. Only handle the power-cord by the plug. Never pull out the plug by tugging the power-cord.

Keep the lamp clean. Do not touch the lamp glass with bare hand.

The projector should always be installed with a secondary safety fixing. A safety cord is supplied for this; it should be attached as shown in "installing the projector" section.

The lamp used in this projector is a discharge lamp. After switching off don't attempt to restart the projector until lamp has cooled, this will require approx 15 minutes. Switching the lamp on and off at short intervals will reduce the life of both the lamp and the projector. But occasional breaks will prolong the life of the lamp and projector.

Never run the projector without a lamp.

The lamp shall be changed if it has become damaged or thermally deformed.

Shields and lens shall be changed if they have become visibly damaged to such an extent than their effectiveness is impaired, for example by cracks or deep scratches. 

Exterior surface temperatures of the luminaire after 5 minutes operation is 80°C, when steady state is achieved 120°C,

There is no user serviceable parts inside the projector, do not open the housing and never operate the projector with the covers removed.

Always disconnect from the mains, when the device is not in use or before cleaning it or before attempting any maintenance work !

If you have any questions, don't hesitate to consult your dealer or manufacturer.

INSTALL THE PROJECTOR

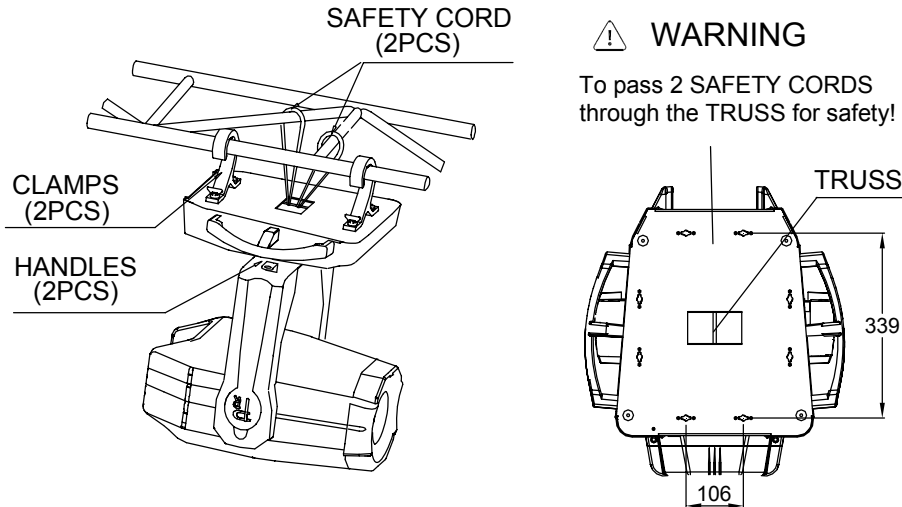

WARNING
To pass 2 SAFETY CORDS through the TRUSS for safety!

Take 2 clamps and 2 safety cords out from the package and mount 2 clamps on the underside of fixture with 2 retainers attached to each clamp. Hang the fixture on the structure and fasten the screws attached to each clamp. (See the **WARNING** on the underside of the base as shown above) **To pass 2 SAFETY CORDS through the truss for safety!** Always ensure that the projector is firmly anchored to avoid vibration and slipping whilst functioning. Always ensure that the structure that you are going to mount the projector is secure and is strong enough to support a weight of XL 700.

WARNING:

1. Unlock the PAN and TILT before the 1st application of projector for safety.
2. The projector **MUST** be lifted or carried by the HANDLES instead of clamps.
3. For safety the safety cord should afford 10 times of the unit's weight.

FITTING THE LAMP

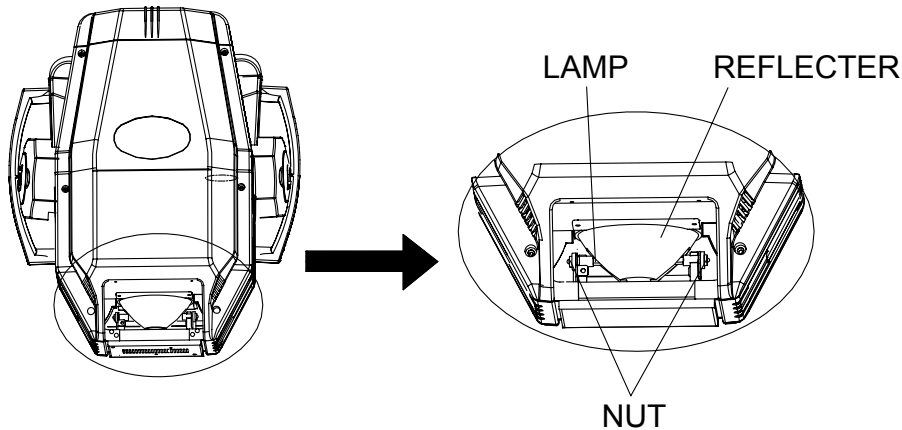

Lock the yoke before fitting/replacing the lamp.

Loosen 4 screws and open the back covers, you can see the structure as shown in the figure above.

Loosen 2 nuts at the both ends of lamp and take out the worn-out lamp. Suggest to free one end after another.

Fit new lamp and fasten 2 screws at the both ends of lamp. **Note:** don't touch the bulb of the new lamp with bare hand so as not to influence the beam output; the PST (pumping stem tip off) on the bulb facing the rear cover with fans perpendicularly and being not in the beam's way is a must and aids cooling.

Close the rear cover and fasten 4 screws.

NOTE: The convex of the nuts should face to the side when fitting the lamp.

WARNING: The MSR series are high-pressure lamps with external igniters (⚠). Care should always be taken when handling these lamps. Always read the manufacturers "Instructions for use" enclosed with the lamp.

POWER SUPPLY-MAINS

Connect the power cord as follows:

- L (live) =brown
- E (earth) =yellow/green
- N (neutral) =blue

Use the plug provided to connect the mains power to the projector paying attention to the voltage and frequency marked on the panel of the projector. It is recommended that each projector be supplied separately so that they may be individually switched on and off.

IMPORTANT

It is essential that each projector is correctly earthed and the electrical installation conforms to all relevant standards.

CONTROL CONNECTION

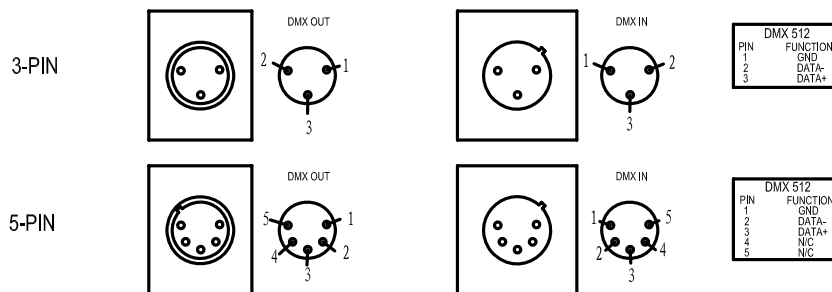

Connection between controller and projector and between one projector and another must be made with a 2 core-screened cable, with each core having at least a 0.5mm diameter. Connection to and from the projector is via cannon 3 pin (which are included with the projector) or 5 pin XLR plugs and sockets. The XLR's are connected as shown in the figure above.

Note: care should be taken to ensure that none of the pins touch the metallic body of the plug or each other. The body of the plug is not connected in any way. The XL 700 accepts digital control signals in protocol DMX512 (1990).

Connect the controller's output to the first fixture's input, and connect the first fixture's output to the second fixture's input and connect the rest fixtures in the same way. Eventually connect the last fixture's output to a DMX terminator as shown in the figure below.

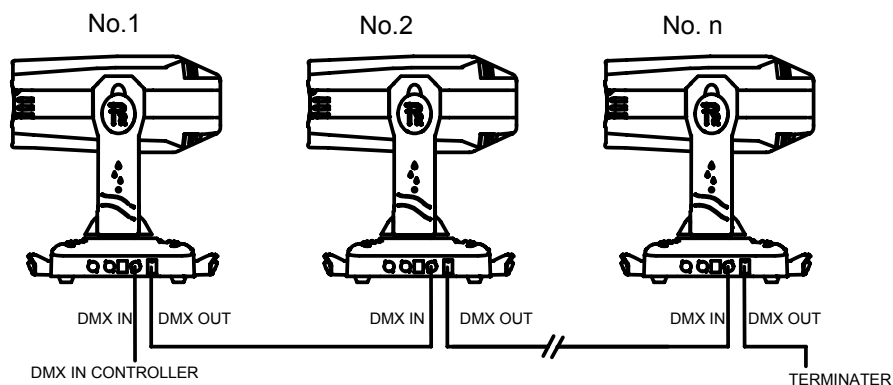

DMX TERMINATOR

In the Controller mode, at the last fixture in the chain, the DMX output has to be connected with a DMX terminator. This prevents electrical noise from disturbing and corrupting the DMX control signals.

The DMX terminator is simply an XLR connector with a 120Ω (ohm) resistor connected across pins 2 and 3, which is then plugged into the output socket on the last projector in the chain. The connections are illustrated below.

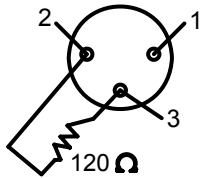

**DMX TERMINATOR
CONNECTION**

Connect a 120Ω(OHM) resistor
across pins 2 and 3 in an XLR plug
and insert into the DMX out socket
on the last unit in the chain.

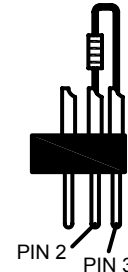

SETUP OPTIONS-PROJECTOR CONFIGURATION

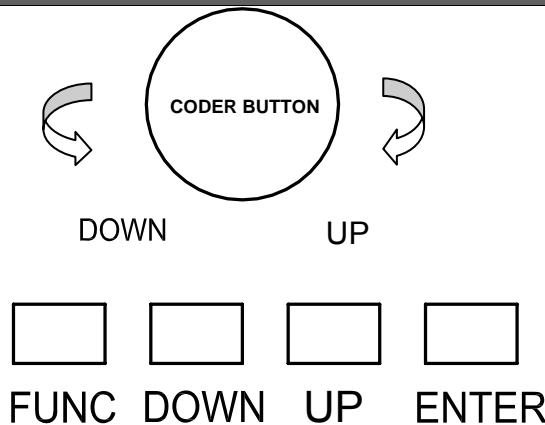

Projector configuration can be set conveniently via pressbutton switch and LCD display. Turn the projector on and the LCD display will show DMX address you set and save last time and it can be reset and saved again as you please.

Launch the projector. Press button **ENTER** more than 5 seconds to unlock panel.

Press button **UP** or **DOWN** if you want to browse through the various Setup Options. There are 8 option codes from **DMX Address** to **Lamp Manual Control**, and each code has a specific function. If you turn the coder knob clockwise, the function like as button **UP**. On the contrary, the function like as button **DOWN**.

Press button **ENTER** to save your settings or enter the next menu. There is same function if you push the coder knob.

Press button **UP** or **DOWN** to shift.

Press button **FUNC**, it will return to the upper menu one by one. If you stay for minutes defaulted will show display status automatically.

TO SET THE DMX START ADDRESS

Each XL 700 must be given a DMX start address so that the correct projector responds to the correct control signals.

This DMX start address is the channel number from which the projector starts to "listen" to the digital control information being sent out from the controller. The XL 700 has 3 DMX modes. There are standard mode, extended mode and short mode. For example standard mode has 24 channels, so set the No. 1 projector's address 001, No. 2 projector's address 025, No. 3 projector's address 049, No. 4 projector's address 073, and so on.

Launch the projector. Press button **ENTER** or coder knob more than 5 seconds to unlock panel.

Press button **FUNC** to display **DMX address**;

Press button **UP** and **DOWN**, you can set the address;

Press button **ENTER** to confirm; In the same time. The GREEN LED will flash one time. It means the setting has been enabled.

Press button **FUNC**, it will return to the upper menu one by one.

OPERATION MENU

1st LEVEL	2nd LEVEL	3rd LEVEL	4th LEVEL	
PR LIGHTING XL SERIES XL 700	DMX Address=001			
DMX Address	DMX Address 001-493 in Short Mode 001-489 in Stand Mode 001-482 in EXtended Mode			
Reset	Reset Are You Sure?			
Config Settings	DMX Mode	DMX Mode Standard 16		
		DMX Mode Extended 16		
		DMX Mode Short 8		
	Lamp Control	Lamp Control By Control Channel		
		Lamp Control By Power On		
		Lamp Control By DMX Present		
	Loss of DMX	When DMX is Lost Normal Time Out		
		When DMX is Lost Hold Last Value		
	Factory Settings (Press button DOWN/UP/ENTER at the same time to enter the sub-menu)	(WARNING: Never change the fixture type or the system will be damaged!)	Fixture type= XL 1200	
			Fixture type= XL 700	
			Fixture type= XL 575	
			Fixture type= XL 1200 FS	
			Fixture type= XL 1200 Wash	
			Fixture type= XL 700 Wash	
			Fixture type= XL 1800	
Fixture type= XL 1500				
Fixture type= XL 1500 Wash				
Fixture type= XL 1500 FS				
Fixture type= XL 1200S				
Option Settings	Colour Positions	Colour Positions STEPPED		
		Colour Positions LINEAR		
	F-Gobo Positions	F-Gobo Positions STEPPED		
		F-Gobo Positions LINEAR		
	Pan DMX Invert	Pan DMX Invert OFF		
		Pan DMX Invert ON		
	Tilt DMX Invert	Tilt DMX Invert OFF		
		Tilt DMX Invert ON		
	Pan Tilt Swap	Pan Tilt Swap OFF		
		Pan Tilt Swap ON		

	Dimmer Invert	Dimmer Invert OFF		
		Dimmer Invert ON		
	Iris Invert	Iris Invert OFF		
		Iris Invert ON		
	Zoom Invert	Zoom Invert OFF		
		Zoom Invert ON		
	CMY Invert	CMY Invert OFF		
		CMY Invert ON		
	Defaults	Defaults OFF		
		Defaults Restore Defaults		
	Display Options	Display Mode	Display On Always	
			Display Off After Delay	
		Display Invert	Display Invert OFF	
			Display Invert ON	
Display Dimming		Disp Dim Level Min		
		Disp Dim Level 1		
		Disp Dim Level 2		
		Disp Dim Level 3		
		Disp Dim Level 4		
		Disp Dim Level 5		
		Disp Dim Level 6		
		Disp Dim Level 7		
		Disp Dim Level 8		
		Disp Dim Level 9		
Disp Dim Level Full				
Display Contrast	Display Contrast XXX(1~36, Default is 16)			
Display Language	Language = English			
	Language = Chinese			
Information	Lamp Hours	Lamp Hours = XX	Reset Lamp Hours Are You Sure?	
	Total Hours	Total Hours = XX		
	Temperature	Display Board	Display Board = XX°C	
		Driver Board 1	Driver Board 1 = XX °C	
		Driver Board 2	Driver Board 2 = XX °C	
		Driver Board 3	Driver Board 3 = XX °C	
Pan and Tilt	Pan and Tilt = XX °C			
Head Sensor	Head Sensor= XX °C			

Software Version	Display Board	Display Board = X.X.X	
	Driver Board 1	Driver Board 1 = X.X.X	
	Driver Board 2	Driver Board 2 = X.X.X	
	Driver Board 3	Driver Board 3 = X.X.X	
	Pan and Tilt	Pan and Tilt = X.X.X	
	Power Board	Power Board = X.X.X	
View DMX values	DMX Channel 1=0		
Electronic SN	Electronic SN= *****		
RDM Device Label	RDM Device Label ANSI E1.20 RDM Version		
Test Modes	Factory Setup	Factory Setup OFF	
		Factory Setup ON	
	Self Test	Self Test OFF	
		self test ON	
Lamp Manual Control	Lamp Status	Status = XXX Control = X	
	Turn Lamp On		
	Turn Lamp Off		

ERROR MESSAGES

In the course of launch, XL 700 examines automatically whether there are errors and if there are, it will display information as follows:

Display	Message
Sensor Err S1-M1	CYM-cyan (1# drive board motor 1) error
Sensor Err S1-M2	CYM-yellow (1# drive board motor 2) error
Sensor Err S1-M3	CYM-magenta (1# drive board motor 3) error
Sensor Err S1-M4	Colour wheel (1# drive board motor 4) error
Sensor Err S2-M1	Rotating Gobo wheel 1 (2# drive board motor 1) error
Sensor Err S2-M2	Gobo rotation (2# drive board motor 2) error
Sensor Err S2-M4	Fixed Gobo wheel (2# drive board motor 4) error
Sensor Err S3-M1	Effects wheel (3# drive board motor 1) error
Sensor Err S3-M3	Prism (3# drive board motor 3) error
Sensor Err S3-M4	Prism rotation (3# drive board motor 4) error
Sensor Err S3-M5	Focus (3# drive board motor 5) error
Sensor Err S3-M6	Zoom (3# drive board motor 6) error

REPLACING GOBOS

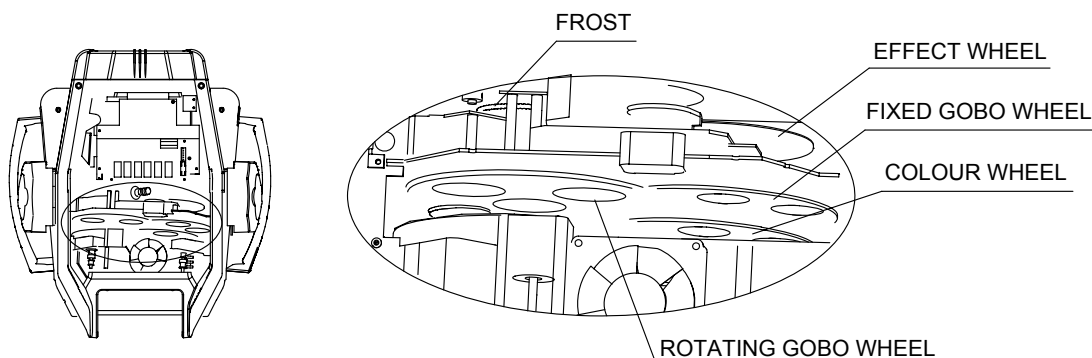

Disconnect the fixture from power. Lock Tilt. Carefully lift off the cover by undoing the 6 screws.

For gobos replacement on the fixed gobo: Remove the gobo and insert the new one into the position by hands.

For gobos replacement on the rotating gobo wheel: Remove the gobo holder with gobo from gobo wheel by hands.

Pull out the spring and drop the old gobo out of the holder.

Insert the new gobo into the holder, and then insert the spring with the narrow end against the gobo.

Push the end of the spring in under lip of the holder.

Pick the spring clip up and put the gobo holder back into the position, if necessary, a small screwdriver will be helped.

Note: If the gobo is a glass one, it should be touched with glabrous, clean and soft tissue or cloth matted between hand and glass instead of with bare hand.

Close the rear cover and fasten 6 screws.

DMX PROTOCOL

Short mode	Standard mode	Extended mode	FUNCTION	DMX	DESCRIPTION
1	1	1	Strobe	000-010	Black
				011-025	Open
				026-225	Strobe speed from slow to fast
				226-255	Open
2	2	2	Dimmer	000-007	Black
				008-255	Dimming from dark to light (0-100%)
		3	Dimmer Fine	000-255	Dimmer in 16 Bit precision
3	3	4	CYM Macro	000-016	White
				017-035	Yellow+ Magenta=Red
				036-054	Yellow
				055-073	Yellow+ Cyan=Green
				074-092	Cyan
				093-110	Cyan+ Magenta=Blue
				111-128	Magenta
				129-255	CYM colour mixing from slow to fast
4	4	5	CYM-Cyan	000-255	Cyan (Linear 0-100%)
		6	CYM-Cyan Fine	000-255	Cyan in 16 Bit precision
5	5	7	CYM-Yellow	000-255	Yellow (Linear 0-100%)
		8	CYM-Yellow Fine	000-255	Yellow in 16 Bit precision
6	6	9	CYM-Magenta	000-255	Magenta (Linear 0-100%)
		10	CYM-Magenta Fine	000-255	Magenta in 16 Bit precision
7	7	11	Colour Wheel	000-016	White
				017-024	White/colour 1
				025-032	Colour 1
				033-040	Colour 1/colour 2
				041-048	Colour 2
				049-056	Colour 2/colour 3
				057-064	Colour 3
				065-072	Colour 3/colour 4
				073-080	Colour 4
				081-088	Colour 4/colour 5
				089-096	Colour 5
				097-104	Colour 5/colour 6
				105-112	Colour 6
				113-120	Colour 6/colour 7
				121-127	white
				128-133	Rainbow rotation speed 1 (slowest)
				134-139	Rainbow rotation speed 2
140-145	Rainbow rotation speed 3				
146-151	Rainbow rotation speed 4				

				152-157	Rainbow rotation speed 5
				158-163	Rainbow rotation speed 6
				164-169	Rainbow rotation speed 7
				170-175	Rainbow rotation speed 8
				176-181	Rainbow rotation speed 9
				182-187	Rainbow rotation speed 10
				188-195	Stop in current position
				196-201	Rainbow reverse rotation speed 1(slowest)
				202-207	Rainbow reverse rotation speed 2
				208-213	Rainbow reverse rotation speed 3
				214-219	Rainbow reverse rotation speed 4
				220-225	Rainbow reverse rotation speed 5
				226-231	Rainbow reverse rotation speed 6
				232-237	Rainbow reverse rotation speed 7
				238-243	Rainbow reverse rotation speed 8
				244-249	Rainbow reverse rotation speed 9
				250-255	Rainbow reverse rotation speed 10
8	8	12	Iris	000-135	Iris from large to small (0-100%)
				136-231	Macro
				232-255	Minimal
		13	Iris Fine	000-255	Iris in 16 Bit precision
9	9	14	Fixed Gobo Wheel	000-016	Clear
				017-032	Gobo1
				033-048	Gobo 2
				049-064	Gobo 3
				065-080	Gobo 4
				081-096	Gobo 5
				097-112	Gobo 6
				113-127	Gobo 7
				128-132	Reverse rotation speed 1 (slowest)
				133-135	Reverse rotation speed 2
				136-138	Reverse rotation speed 3
				139-141	Reverse rotation speed 4
				142-144	Reverse rotation speed 5
				145-147	Reverse rotation speed 6
				148-150	Reverse rotation speed 7(fastest)
				151-153	Rotation speed 1 (slowest)
				154-156	Rotation speed 2
				157-159	Rotation speed 3
				160-162	Rotation speed 4
				163-165	Rotation speed 5
				166-168	Rotation speed 6
				169-171	Rotation speed 7(fastest)
				172-174	Gobo 1 shake 1(slowest)
				175-177	Gobo 1 shake 2
				178-180	Gobo 1 shake 3
				181-183	Gobo 1 shake 4 (fastest)
				184-186	Gobo 2 shake 1(slowest)
				187-189	Gobo 2 shake 2

				190-192	Gobo 2 shake 3
				193-195	Gobo 2 shake 4 (fastest)
				196-198	Gobo 3 shake 1(slowest)
				199-201	Gobo 3 shake 2
				202-204	Gobo 3 shake 3
				205-207	Gobo 3 shake 4 (fastest)
				208-210	Gobo 4 shake 1(slowest)
				211-213	Gobo 4 shake 2
				214-216	Gobo 4 shake 3
				217-219	Gobo 4 shake 4 (fastest)
				220-222	Gobo 5 shake 1(slowest)
				223-225	Gobo 5 shake 2
				226-228	Gobo 5 shake 3
				229-231	Gobo 5 shake 4 (fastest)
				232-234	Gobo 6 shake 1(slowest)
				235-237	Gobo 6 shake 2
				238-240	Gobo 6 shake 3
				241-243	Gobo 6 shake 4 (fastest)
				244-246	Gobo 7 shake 1(slowest)
				247-249	Gobo 7 shake 2
				250-252	Gobo 7 shake 3
				253-255	Gobo 7 shake 4 (fastest)
				000-021	white
				022-042	Gobo1
				043-064	Gobo 2
				065-085	Gobo 3
				086-106	Gobo 4
				107-127	Gobo 5
				128-134	Rotation speed 1 (slowest)
				135-142	Rotation speed 2
				143-149	Rotation speed 3
				150-156	Rotation speed 4 (fastest)
				157-163	Reverse rotation speed 1 (slowest)
				164-170	Reverse rotation speed 2
				171-177	Reverse rotation speed 3
				178-184	Reverse rotation speed 4(fastest)
				185-191	Gobo 1 shake slow
				192-198	Gobo 1 shake fast
				199-205	Gobo 2 shake slow
				206-212	Gobo 2 shake fast
				213-219	Gobo 3 shake slow
				220-226	Gobo 3 shake fast
				227-233	Gobo 4 shake slow
				234-240	Gobo 4 shake fast
				241-247	Gobo 5 shake slow
				248-255	Gobo 5 shake fast
10	10	15	Rotating Gobo Wheel	000-128	0~540°index
				129-188	Rotation speed from slow to fast
				189-195	Stop rotating
				196-255	Reverse rotation speed from slow to fast
				000-255	Gobo rotation in 16 Bit precision
11	11	16	Gobo rotation		
	12	17	Gobo rotation Fine		

12	13	18	Prism / Frost	000-051	Clear
				052-102	CTO
				103-153	Frost
				154-204	Prism 1
				205-255	Prism 2
13	14	19	Prism rotation	000-120	Prism index (0~540°)
				121-127	Reverse rotation speed 1 (slowest)
				128-135	Reverse rotation speed 2
				136-143	Reverse rotation speed 3
				144-151	Reverse rotation speed 4
				152-159	Reverse rotation speed 5
				160-167	Reverse rotation speed 6
				168-175	Reverse rotation speed 7
				176-183	Reverse rotation speed 8 (fastest)
				184-191	Stop in current position
				192-199	Rotation speed 1 (slowest)
				200-207	Rotation speed 2
				208-215	Rotation speed 3
				216-223	Rotation speed 4
				224-231	Rotation speed 5
				232-239	Rotation speed 6
				240-247	Rotation speed 7
248-255	Rotation speed 8 (fastest)				
14	15	20	Effect Wheel	000-020	White
				021-255	Wheel full into beam gradually
15	16	21	Effect Wheel Rotation	000-125	Rotation speed from fast to slow
				126-141	Stop in current position
				142-255	Reverse rotation speed from slow to fast
16	17	22	Focus	000-255	Linearly focusing
		23	Focus Fine	000-255	Focus in 16 precision
17	18	24	Zoom	000-255	From large to small
		25	Zoom Fine	000-255	Zoom in 16 precision
18	19	26	Pan	000-255	Pan rotation 450°
	20	27	Pan Fine	000-255	Pan rotation in 16 precision
19	21	28	Tilt	000-255	Tilt rotation 270°
	22	29	Tilt Fine	000-255	Tilt rotation in 16 precision
	23	30	Pan & Tilt speed	000-255	Pan & Tilt speed from fast to slow
20	24	31	Control	000-048	Reserved
				049-080	Reset
				081-112	Reserved
				113-144	Lamp off (stop in DMX value for 10 s)
				145-168	Reserved
				169-200	Lamp power reduced to 50%
				201-223	Reserved
				224-255	Lamp on (See remark below)

Remark:

If you intend to turn on/off the lamp via the last channel of the controller, don't attempt to push the channel to value 224-255 immediately after turning it off, or push the slide bar to value 224-255 to wait it cooling. Under these 2 circumstances, the lamp can not be turned on. The right operation is: turn it off—cool down—push the slide bar to turn it on.

LED INDICATION

Green	On	DMX signal OK
	Off	No DMX signal
	Flash	DMX signal error
Yellow	On	Setting the panel
Blue	On	Power
Red/Green	Red	Running self test mode
	Green	Reserved

MAINTENANCE

If the projector's lens becomes damaged or broken it should be replaced. If the lamp becomes damaged or deformed in any way it must be replaced. If the light from the lamp appears dim this would normally indicate that it is reaching the end of its life and it should be changed at once, aged lamps run to the extremity of their life might explode. If the projector does not function, check the fuses on the power socket of the projector, they should only be replaced by fuses of the same specification. Should these be damaged call a qualified technician before replacement. The projector has thermal protection device that will switch off the projector in case of overheating, should either of these operate, check that the fans are not blocked, and if they are dirty clean them before switching on the projector again. Check that the fans are operational, if not call a qualified technician.

Any maintenance work should only be carried out by qualified technicians.

LUBRICATION

To ensure the continuous rotation of the rotating gobos and linear motion of the lens for focusing, it is recommended that the bearings for the rotating gobos and the 2 shafts for the focusing lens holder be lubricated periodically, preferably every two months. Use only high quality, high-temperature resistant grease instead of any type of oil. When lubricating the bearings, a syringe with a fine needle is the easiest way to introduce the grease to the bearings around each gobo.

KEEPING THE PROJECTOR CLEAN

To ensure the reliability of the projector it should be kept clean. It is recommended that the fans should be cleaned every 15 days. The lens and dichroic colour filters should also be regularly cleaned to maintain an optimum light output. **Do NOT use any type of solvent on dichroic colour filters.**

Cleaning frequency depends on the environment in which the fixture operates: damp, smoke or particularly dirty surroundings can cause greater accumulation of dirt on the unit's optics. A soft cloth and typical glass cleaning products should be used in cleaning. It is recommended to clean the external optics at least once every 20 days and clean the internal optics at least once every 30 / 60 days.

Do not use any organic solvent, e.g. alcohol, to clean the reflector mirror, dichroic colour filters or housing of the apparatus.

TROUBLESHOOTING

PROBLEM	ACTION
The projector doesn't switch on	<ul style="list-style-type: none"> ➤ Check the fuse on the power socket. ➤ Replace the lamp.
The lamp comes on but the projector doesn't respond to the controller	<ul style="list-style-type: none"> ➤ Make sure that the projector is correctly configured. ➤ Replace or repair the DMX cable.
The projector only functions intermittently	<ul style="list-style-type: none"> ➤ Make sure the fan is working and not dirty.
Defective projection	<ul style="list-style-type: none"> ➤ Check the lenses are not broken. ➤ Remove dust or grease from the lenses.
The project image appears to have a halo	<ul style="list-style-type: none"> ➤ Make sure the lamp is installed correctly. ➤ Carefully clean the optical group lenses and the projector components.
The beam appears dim	<ul style="list-style-type: none"> ➤ Check the optics is clean. ➤ Replace with a new lamp of the specified type and rating.

TECHNICAL DATA

VOLTAGES:

100V/120V/200V/220V/230V/240V AC, 50/60Hz

POWER CONSUMPTION:

830W@220V

LAMP:

PHILIPS	MSR 700 SA/2 DE
Colour Temperature	7500°K
Socket	SFc10-4, double ended
Manufacturers Rated Lamp Life	750 Hours replacement
Or	
OSRAM	SharXS HTI 700 W/D4/60
Colour Temperature	6000°K
Socket	SFc10-4, double ended
Manufacturers Rated Lamp Life	750 Hours replacement

COLOURS:

Smooth CYM colour mixing system with macros

1 wheel with 6 dichroic colour filters plus white

With variable speed bi-directional rainbow effect

Step/linear colour changing is available

GOBOS:

1 Rotating gobo wheel:

5 interchangeable gobos+ white, glass or metal gobos can be fixed

Indexable, bi-directionally rotatable at variable speeds

1 Fixed gobo wheel :

7 interchangeable gobos+ white

bi-directional wheel scrolling at variable speeds

Gobo diameter: Φ 36.3mm

Gobo image diameter: Φ 31.5mm

PRISM/ FROST:

1x linear lens, 1x3 facet prism, indexable, bi-directionally rotatable at variable speeds

1x frost, 1xCTO

EFFECT FILTERS:

1 interchangeable gobo effect wheel scrolling at variable speeds

FOCUS:

DMX controlled focus

DIMMER:

0-100% linearly adjustable

SHUTTER:

Double shutter blades, 0.3~12 F.P.S

HEAD MOVEMENT:

Pan 450°, Tilt 270° with auto position correction

BEAM ANGLE:

12° ~34° , linearly adjustable

CONTROL:

DMX512, 3 pin interface

RDM control protocol

20 channels in short mode, 24 channels in standard mode, and 31 channels in extended mode.

Self-test mode

OTHER FUNCTIONS:

Adjustable Pan & Tilt speed

Fixture and lamp usage time display

LCD display with English and Chinese language menu

Energy saving function of the ballast

Built-in analyzer for easy fault finding, error messages

Built-in demo sequences

Setup options by chargeable battery inside without power connection.

Input signal isolating protection

Network interface (Reserved)

HOUSING:

Composite plastic, IP20

WEIGHT:

30Kg

SIZES:

See at below

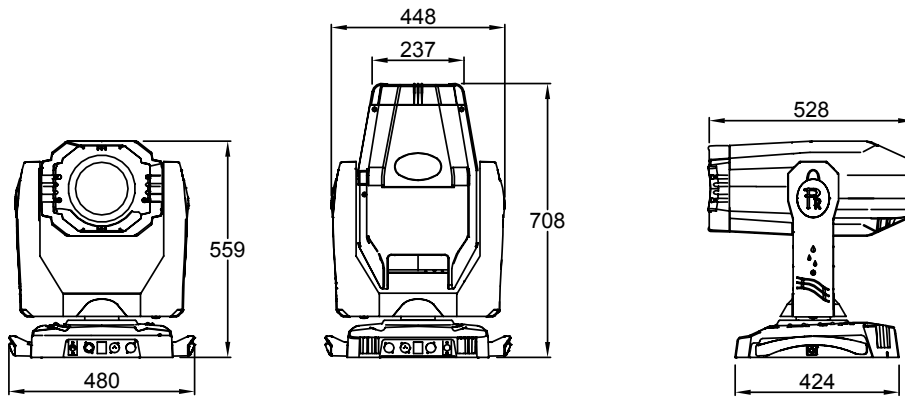

LIGHT OUTPUT:

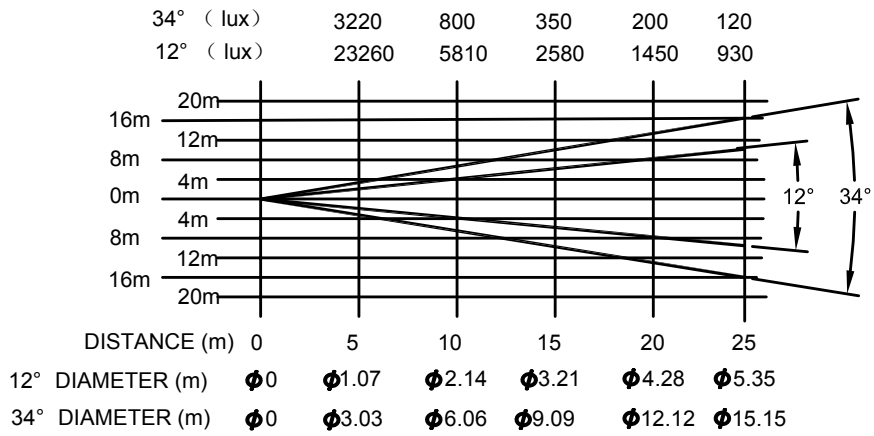

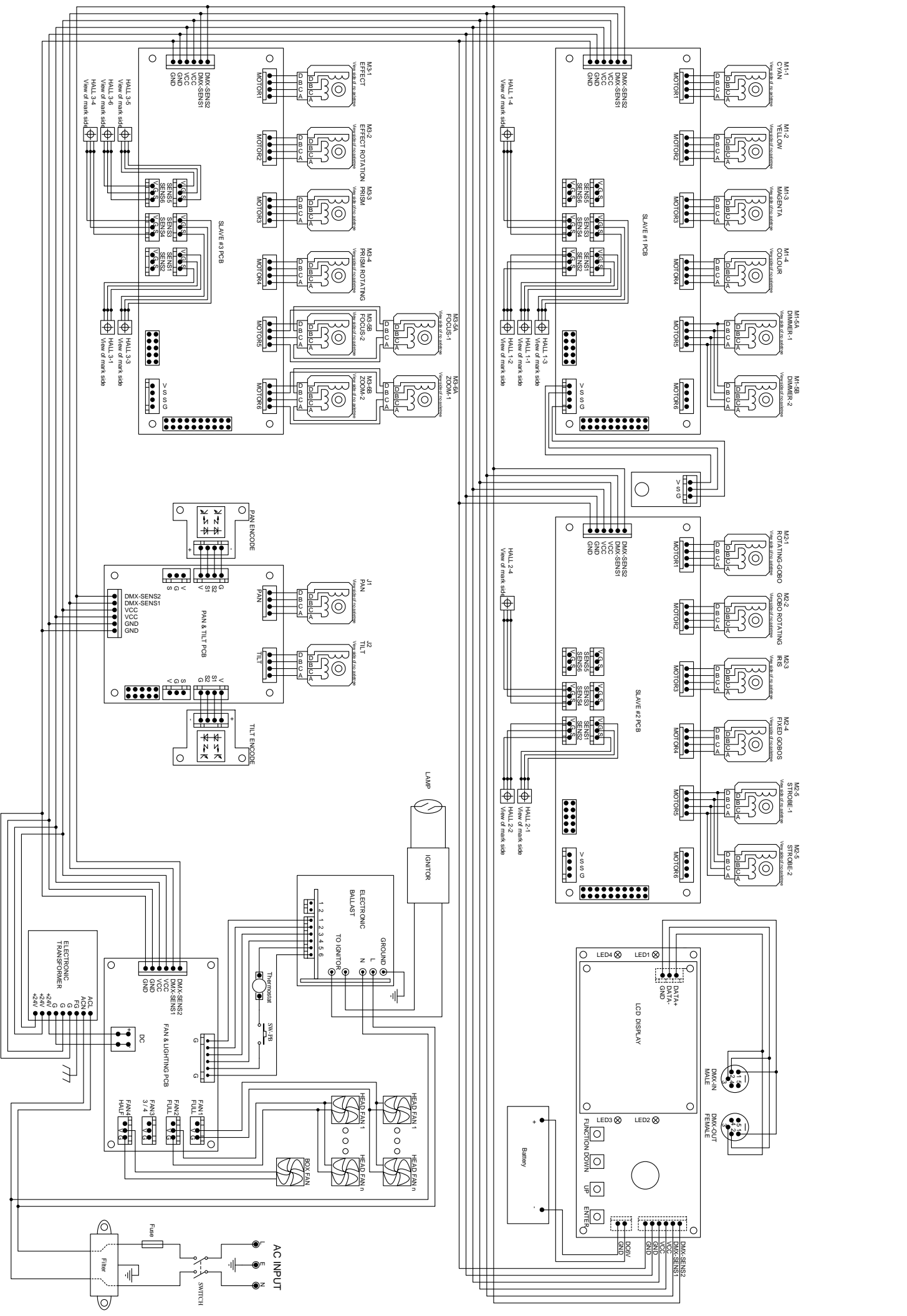

COMPONENT ORDER CODES

NAME	PART NO.	QUANTITY	REMARK
POWER SUPPLY	192010134	1	S-320-24
MAINS FILTER	193020008	1	20A 115/250VAC
THERMOSTAT	190010103	1	KSD020-00/16/15A-1056
SWITCH	190010050	1	16A 250V/20A 125VAC
BALLAST	040070087	1	MHS700A5Z RC
IGNITOR	040090043	1	575~1200W
LAMP	100050061	1	MSR 700W SA/2 DE
TILT DRIVE BELT	290151241	1	HTD-750-3M
PAN DRIVE BELT	290151234	1	HTD-501-3M
FAN IN FRONT SIDE	030060053	2	DC 24V/0.21A
FAN IN BACK SIDE	030060055	2	DC 24V/0.16A
FAN NEAR THE COLOUR WHEEL	030060062	1	DC 24V/0.20A
FAN NEAR THE LAMP		2	
FAN NEAR THE CYM	030060052	2	DC 24V/0.09A
PAN MOTOR	030040089	1	23HS2039L 6.35*25
TILT MOTOR		1	
PRISM ROTATION MOTOR	030040131	1	16HY0002-02L 5*24
ROTATING GOBO WHEEL MOTOR	030040092	1	17HD0013-32L 5*7
PRISM/FROST MOTOR		1	
DIMMER MOTOR	030040093	2	17HD0013-33L 5*35
FOCUS MOTOR	030040073	2	17HD5003-09L 5*20
ZOOM MOTOR		2	
GOBO ROTATION MOTOR	030040132	1	17HD0013-31L 5*23
CYM-CYAN MOTOR	030040114	1	16HY7001-30L 5*40
CYM-YELLOW		1	
CYM-MAGENTA MOTOR		1	
EFFECT WHEEL ROTATION MOTOR		1	
FIXED GOBO WHEEL MOTOR	030040136	1	16HS7002 5*17
COLOUR WHEEL MOTOR	030040115	1	16HY7001-44 5*18
SHUTTER BLADE MOTOR	030040116	2	16HY7001-32L 5*15
IRIS MOTOR	030040088	1	39BYG501-4A 5*24
EFFECT WHEEL MOTOR	030040118	1	16HY7001-34L 5*12*10
PAN/TILT DRIVE PCB	230020317	1	
MOTOR DRIVE PCB 1	230020212	1	
MOTOR DRIVE PCB 2	230020213	1	
MOTOR DRIVE PCB 3	230020214	1	
DISPLAY PCB	230020220	1	
POWER PCB	230020223	1	

PR LIGHTING LTD.

1582 Xingye Avenue, Nancun Panyu
Guangzhou, 511442 China
TEL: +86-20-3995 2888
FAX: +86-20-3995 2330

P/N: 321010256B
Last Revision: 20090827